

**IT - PENTOLE GAS**

APPENDICE: Tabella B - Pressione gas/dati tecnici ugelli

**GB-IE - GAS POTS**

APPENDIX: Table B - Gas pressure/nozzle technical data

**DE - KOCHKESSEL**

ANHANG: Tabelle B - Gasdruck/technische Daten der Düsen

**FR - BE - CASSEROLES À GAZ**

APPENDICE : Tableau B - Pression du gaz/caractéristiques techniques des buses

**BE - PANNEN GAS**

BIJLAGE: Tabel B - Gasdruk/technische gegevens sproeiers

**ES - MARMITAS DE GAS**

APÉNDICE: Tabla B - Presión del gas/datos técnicos de las boquillas

**NL - PANNEN GAS**

BIJLAGE: Tabel B - Gasdruk/technische gegevens sproeiers

**PT - CALDEIRÕES A GÁS**

APÉNDICE: Tabela B - Pressão do gás/dados técnicos dos bicos

**DK - KOGEGRYDER TIL GAS**

APPENDIKS: Tabel B - Gastryk/tekniske specifikationer for dyser

**SE - GASDRIVEN KOKGRYTA**

BILAGA: Tabell B - Gastryck/Tekniska data för dysor

**NO - GASSGRYTER**

TILLEGG: Tabell B - Gasstrykk/tekniske data dyser

**AT - CH -**

ANHANG: Tabelle B - Gasdruck/technische Daten der Düsen

**FI - KEITTOPADAT KAASU**

LIITE: Taulukko B - Kaasun paine/suuttimien tekniset tiedot

**EE - GAASIKATLAD**

LISA: TABEL B – Tehnilised andmed gaasi rõhu ja düüsi kohta

**LT - DUJINIAI PUODAI**

PRIEDAS: lentelė B - dujų slėgio / purkštukų techniniai duomenys

**LV - VĀRĪĀNAS KATLI**

PIELIKUMS: Tabula B - Gāzes spiediens/tehniskie uzgaļu dati

**CZ - PLYNOVÉ KOTLE**

PŘÍLOHA: Tabulka B - Tlak plynu/technické údaje trysek

**SK - HRNCE NA PLYN**

PŘÍLOHA: Tabuľka B - Tlak plynu/technické údaje o dýzách

**PL - GAZOWE KOTŁY WARZELNE**

ZAŁĄCZNIK: Tabela B - Ciśnienie gazu / dane techniczne dysz

**HU - GÁZÜZEMŰ KUKTÁK**

MELLÉKLET: B. táblázat - Gáznyomás/fűvóka műszaki adatai

**SL - PLINSKI KUHALNIK**

DODATEK: Tabela B - tlak plina / tehnični podatki o šobah

**GR - ΒΡΑΣΤΗΡΕΣ ΑΕΡΙΟΥ**

ΠΑΡΑΡΤΗΜΑ: Πίνακας Β - Πίεση αερίου/τεχνικά χαρακτηριστικά μπεκ

**IS - MT - GASPOTTAR**

VIÐBÆTIR: Tafla B - Gas þrýstingur/tæknilegar upplýsingar um gasstúta (spíssa)

**LU - CASSEROLES À GAZ**

APPENDICE : Tableau B - Pression du gaz/caractéristiques techniques des buses

**CY - ΒΡΑΣΤΗΡΕΣ ΑΕΡΙΟΥ**

ΠΑΡΑΡΤΗΜΑ: Πίνακας Β - Πίεση αερίου/τεχνικά χαρακτηριστικά μπεκ

**BG - ТЕНДЖЕРИ НА ГАЗ**

ПРИЛОЖЕНИЕ: Таблица В - Налягане на газта/технически данни на дюзите

**RO - OALE GAZ**

ANEXĂ: Tabelul B - Presiune gaz/date tehnice duze

**TR - GAZLI GÜVEÇ**

EK: Tablo B - Gaz basıncı / ayar uçları teknik verileri

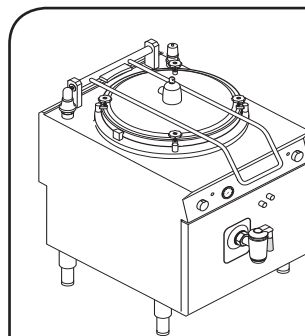
**CE**DOC. NO.  
EDITION 1**59589A302**  
03 2015

## IT. ITALIA (categoria II2H3+)

TABELLA B - Pressione gas e dati ugelli														
TIPO GAS			G20						G30/G31					
			Nominale		Minima		Massima		Nominale		Minima		Massima	
PRESSIONE GAS		(mbar)	20		17		25		28-30/37		20/25		35/45	
BRUCIATORI	Ø (mm)	kW	Aereatore	Ugello MAX		Ugello MIN		Pilota	Aereatore	Ugello MAX		Ugello MIN		Pilota
			mm	mm	Stamp.	mm	Stamp.	n°	mm	mm	Stamp.	mm	Stamp.	n°
Diretta 60L Indiretta 60L	- -	- -	32	2,90	290	-	-	41	28	1,85	185	-	-	30
Diretta 100L Indiretta 100L	- -	- -	32	2,50	250	-	-	41	30	1,65	165	-	-	30
Diretta 150L Indiretta 150L	- -	- -	33	2,60	260	-	-	41	30	1,75	175	-	-	30
Potere calorifico inferiore (Hi)			34.02 Mj/m3						45.65 Mj/Kg (Gas G30)					
Consumo gas complessivo (con potere calorifico inferiore(Hi) a 15°C e 1013mbar)														
MODELLI	+9BSGHINF0		1,48 m3/h						1,10 Kg/h					
	+9BSGHDPF0		2,22 m3/h						1,66 Kg/h					
	+9BSGHIPF0		2,22 m3/h						1,66 Kg/h					
	+9BSGHIPFR		2,22 m3/h						1,66 Kg/h					
	+9BSGHDRF0		2,54 m3/h						1,89 Kg/h					
	+9BSGHDRFW		2,54 m3/h						1,89 Kg/h					
	+9BSGHIRF0		2,54 m3/h						1,89 Kg/h					
	+9BSGHIRFR		2,54 m3/h						1,89 Kg/h					
	+9BSGHDRFC		2,54 m3/h						1,89 Kg/h					
	+9BSGHIRFC		2,54 m3/h						1,89 Kg/h					

## GB-IE. GREAT BRITAIN - IRELAND (category II2H3+)

TABLE B - Gas pressure and nozzle data														
GAS TYPE			G20						G30/G31					
			Nominal		Min.		Max.		Nominal		Min.		Max.	
GAS PRESSURE		(mbar)	20		17		25		28-30/37		20/25		35/45	
BURNERS	Ø (mm)	kW	Aereatore	Ugello MAX		Ugello MIN		Pilota	Aereatore	Ugello MAX		Ugello MIN		Pilota
			mm	mm	Stamp.	mm	Stamp.	n°	mm	mm	Stamp.	mm	Stamp.	n°
Direct 60L Indirect 60L	- -	- -	32	2,90	290	-	-	41	28	1,85	185	-	-	30
Direct 100L Indirect 100L	- -	- -	32	2,50	250	-	-	41	30	1,65	165	-	-	30
Direct 150L Indirect 150L	- -	- -	33	2,60	260	-	-	41	30	1,75	175	-	-	30
Lower heating power (Hi)			34.02 Mj/m3						45.65 Mj/Kg (Gas G30)					
Total gas consumption (with lower heating power (Hi) at 15°C and 1013mbar)														
MODELS	+9BSGHINF0		1,48 m3/h						1,10 Kg/h					
	+9BSGHDPF0		2,22 m3/h						1,66 Kg/h					
	+9BSGHIPF0		2,22 m3/h						1,66 Kg/h					
	+9BSGHIPFR		2,22 m3/h						1,66 Kg/h					
	+9BSGHDRF0		2,54 m3/h						1,89 Kg/h					
	+9BSGHDRFW		2,54 m3/h						1,89 Kg/h					
	+9BSGHIRF0		2,54 m3/h						1,89 Kg/h					
	+9BSGHIRFR		2,54 m3/h						1,89 Kg/h					
	+9BSGHDRFC		2,54 m3/h						1,89 Kg/h					
	+9BSGHIRFC		2,54 m3/h						1,89 Kg/h					

TABELLE B - Gasdruck und Daten der Düsen															
GASART				G20				G30/G31				G25			
GASDRUCK		(mbar)		Nennndruck	Mindestdruck	Höchstdruck		Nennndruck	Mindestdruck	Höchstdruck		Nennndruck	Mindestdruck	Höchstdruck	
BRENNER	Ø (mm)	kW	Luftring mm	Düse MAX	Düse MIN	Zündflamme	Luftring mm	Düse MAX	Düse MIN	Zündflamme	Luftring mm	Düse MAX	Düse MIN	Zündflamme	
				mm Stempel	mm	Anz.		mm Stempel	mm	Anz.		mm Stempel	mm	Anz.	
Direkt beheizt, 60 Indirekt beheizt, 60 L	-	-	34	2,85	-	41	30	1,60	160	-	30	3,15	315	-	41
Direkt beheizt, 100 Indirekt beheizt, 100 L	-	-	34	2,85	-	41	33	1,45	145	-	30	2,70	270	-	41
Direkt beheizt, 150 Indirekt beheizt, 150 L	-	-	34	2,85	-	41	33	1,55	155	-	30	2,90	290	-	41
Unterer Heizwert (Hi)				34,02 MJ/m <sup>3</sup>				45,65 MJ/Kg (Gas G30)				29,25 MJ/m <sup>3</sup>			
Gesamtgasverbrauch (mit unterem Heizwert (Hi) bei 15°C und 1013 mbar)															
MODELLE		+9BSGHINF0			1,48 m <sup>3</sup> /h				1,10 Kg/h				1,72 m <sup>3</sup> /h		
		+9BSGHDPF0			2,22 m <sup>3</sup> /h				1,66 Kg/h				2,58 m <sup>3</sup> /h		
		+9BSGHIPF0			2,22 m <sup>3</sup> /h				1,66 Kg/h				2,58 m <sup>3</sup> /h		
		+9BSGHIPFR			2,22 m <sup>3</sup> /h				1,66 Kg/h				2,58 m <sup>3</sup> /h		
		+9BSGHDRF0			2,54 m <sup>3</sup> /h				1,89 Kg/h				2,95 m <sup>3</sup> /h		
		+9BSGHDRFW			2,54 m <sup>3</sup> /h				1,89 Kg/h				2,95 m <sup>3</sup> /h		
		+9BSGHIRF0			2,54 m <sup>3</sup> /h				1,89 Kg/h				2,95 m <sup>3</sup> /h		
		+9BSGHIRFR			2,54 m <sup>3</sup> /h				1,89 Kg/h				2,95 m <sup>3</sup> /h		
+9BSGHDRFC			2,54 m <sup>3</sup> /h				1,89 Kg/h				2,95 m <sup>3</sup> /h				
+9BSGHIRFC			2,54 m <sup>3</sup> /h				1,89 Kg/h				2,95 m <sup>3</sup> /h				

TABLEAU B - Pression du gaz et caractéristiques des buses																					
TYPE DE GAZ		G20				G30/G31				G25											
PRESSION DU GAZ		Nominale	Minimum	Maximum	Nominale	Minimum	Maximum	Nominale	Minimum	Maximum	Nominale	Minimum	Maximum								
(mbar)		20/25	17/20	25/30	28-30/37	20/25	35/45	20/25	17/20	25/30	20/25	17/20	25/30								
BRÛLEURS	Ø (mm)	kW	Aérateur		Buse MAX		Buse MIN		Veilleuse gaz		Aérateur		Buse MAX		Buse MIN		Veilleuse gaz				
			mm	mm	mm	Estamp.	mm	Estamp.	mm	Estamp.	n°	mm	mm	mm	Estamp.	mm	Estamp.	n°			
Directe 60L Indirecte 60L	-	-	32	2,90	-	-	-	-	28	1,85	185	-	-	30	32	3,00	300	-	41		
Directe 100L Indirecte 100L	-	-	32	2,50	-	-	-	30	1,65	165	-	-	30	33	2,60	260	-	41			
Directe 150L Indirecte 150L	-	-	33	2,60	-	-	-	30	1,75	175	-	-	30	34	2,75	275	-	41			
Pouvoir calorifique inférieur (HI)		34,02 MJ/m <sup>3</sup>												45,65 MJ/Kg (Gaz G30)		29,25 MJ/m <sup>3</sup>					
Consommation totale de gaz (avec un pouvoir calorifique inférieur (HI) à 15°C et 1013 mbars)																					
+9BSGHINF0		1,48 m <sup>3</sup> /h												1,72 m <sup>3</sup> /h							
+9BSGHDPF0		2,22 m <sup>3</sup> /h												2,58 m <sup>3</sup> /h							
+9BSGHIPF0		2,22 m <sup>3</sup> /h												2,58 m <sup>3</sup> /h							
+9BSGHIPFR		2,22 m <sup>3</sup> /h												2,58 m <sup>3</sup> /h							
+9BSGHDRF0		2,54 m <sup>3</sup> /h												2,95 m <sup>3</sup> /h							
+9BSGHDRFW		2,54 m <sup>3</sup> /h												2,95 m <sup>3</sup> /h							
+9BSGHIRF0		2,54 m <sup>3</sup> /h												2,95 m <sup>3</sup> /h							
+9BSGHIRFR		2,54 m <sup>3</sup> /h												2,95 m <sup>3</sup> /h							
+9BSGHDRFC		2,54 m <sup>3</sup> /h												2,95 m <sup>3</sup> /h							
+9BSGHIRFC		2,54 m <sup>3</sup> /h												2,95 m <sup>3</sup> /h							
MODÈLES																					

# BE. BELGIUM (category II2E+3+)

TABEL B - Gasdruk en gegevens sproeiers													
SOORT GAS		G20				G30/G31				G25			
GASDRUK		Nominaal		Minimaal		Nominaal		Minimaal		Nominaal		Minimaal	
BRANDERS	Ø (mm)	(mbar)		kW		20/25		17/20		25/30		20/25	
		Beluchter	Sproeier MAX	Sproeier MIN	Waakvlambrander	Beluchter	Sproeier MAX	Sproeier MIN	Waakvlambrander	Beluchter	Sproeier MAX	Sproeier MIN	Waakvlambrander
		mm	mm	mm	Opdruk	mm	Opdruk	mm	Opdruk	mm	Opdruk	mm	Opdruk
Direct 60L Indirect 60L	-	32	2,90	290	-	28	1,85	185	-	30	3,00	300	-
Direct 100L Indirect 100L	-	32	2,50	250	-	30	1,65	165	-	30	2,60	260	-
Direct 150L Indirect 150L	-	33	2,60	260	-	30	1,75	175	-	34	2,75	275	-
Verwarmingswaarde van minder (Hi) dan		34,02 MJ/m <sup>3</sup>				45,65 MJ/Kg (Gas G30)				29,25 MJ/m <sup>3</sup>			
Totaal gasverbruik (met een verwarmingswaarde van minder (Hi) dan 15°C en 1013mbar)													
				+9BSGHINF0		1,48 m <sup>3</sup> /h		1,10 Kg/h		1,72 m <sup>3</sup> /h		2,58 m <sup>3</sup> /h	
				+9BSGHDPF0		2,22 m <sup>3</sup> /h		1,66 Kg/h		2,58 m <sup>3</sup> /h		2,58 m <sup>3</sup> /h	
				+9BSGHIPF0		2,22 m <sup>3</sup> /h		1,66 Kg/h		2,58 m <sup>3</sup> /h		2,58 m <sup>3</sup> /h	
				+9BSGHIPFR		2,22 m <sup>3</sup> /h		1,66 Kg/h		2,58 m <sup>3</sup> /h		2,58 m <sup>3</sup> /h	
				+9BSGHDRF0		2,54 m <sup>3</sup> /h		1,89 Kg/h		2,95 m <sup>3</sup> /h		2,95 m <sup>3</sup> /h	
				+9BSGHDRFW		2,54 m <sup>3</sup> /h		1,89 Kg/h		2,95 m <sup>3</sup> /h		2,95 m <sup>3</sup> /h	
				+9BSGHIRF0		2,54 m <sup>3</sup> /h		1,89 Kg/h		2,95 m <sup>3</sup> /h		2,95 m <sup>3</sup> /h	
				+9BSGHIRFR		2,54 m <sup>3</sup> /h		1,89 Kg/h		2,95 m <sup>3</sup> /h		2,95 m <sup>3</sup> /h	
				+9BSGHDRFC		2,54 m <sup>3</sup> /h		1,89 Kg/h		2,95 m <sup>3</sup> /h		2,95 m <sup>3</sup> /h	
				+9BSGHIRFC		2,54 m <sup>3</sup> /h		1,89 Kg/h		2,95 m <sup>3</sup> /h		2,95 m <sup>3</sup> /h	
<b>MODELLEN</b>													

## ES. SPAIN (categoría II2H3+)

TABLA B - Presión del gas y datos de las boquillas														
TIPO DE GAS			G20						G30/G31					
			Nominal		Mínima		Máxima		Nominal		Mínima		Máxima	
PRESIÓN DEL GAS		(mbar)	20		17		25		28-30/37		20/25		35/45	
QUEMADORES	Ø (mm)	kW	Aireador	Boquilla MÁX		Boquilla MIN		Piloto	Aireador	Boquilla MÁX		Boquilla MIN		Piloto
			mm	mm	Grabado	mm	Grabado	n°	mm	mm	Grabado	mm	Grabado	n°
Cal. dir. 60 l Cal. indir. 60 l	-	-	32	2,90	290	-	-	41	28	1,85	185	-	-	30
Cal. dir. 100 l Cal. indir. 100 l	-	-	32	2,50	250	-	-	41	30	1,65	165	-	-	30
Cal. dir. 150 l Cal. indir. 150 l	-	-	33	2,60	260	-	-	41	30	1,75	175	-	-	30
Poder calorífico inferior (Hi)			34.02 MJ/m <sup>3</sup>						45.65 MJ/Kg (Gas G30)					
Consumo total de gas (calculado con poder calorífico inferior (Hi) a 15°C y 1013mbar)														
MODELOS	+9BSGHINF0		1,48 m <sup>3</sup> /h						1,10 Kg/h					
	+9BSGHDPF0		2,22 m <sup>3</sup> /h						1,66 Kg/h					
	+9BSGHIPF0		2,22 m <sup>3</sup> /h						1,66 Kg/h					
	+9BSGHIPFR		2,22 m <sup>3</sup> /h						1,66 Kg/h					
	+9BSGHDRF0		2,54 m <sup>3</sup> /h						1,89 Kg/h					
	+9BSGHDRFW		2,54 m <sup>3</sup> /h						1,89 Kg/h					
	+9BSGHIRF0		2,54 m <sup>3</sup> /h						1,89 Kg/h					
	+9BSGHIRFR		2,54 m <sup>3</sup> /h						1,89 Kg/h					
	+9BSGHDRFC		2,54 m <sup>3</sup> /h						1,89 Kg/h					
	+9BSGHIRFC		2,54 m <sup>3</sup> /h						1,89 Kg/h					

## NL. THE NETHERLANDS (category II2L3B/P)

TABEL B - Gasdruk en gegevens sproeiers														
SOORT GAS			G25						G30/G31					
			Nominaal		Minimaal		Maximaal		Nominaal		Minimaal		Maximaal	
GASDRUK		(mbar)	25		20		30		30		25		35	
BRANDERS	Ø (mm)	kW	Beluchter	Sproeier MAX		Sproeier MIN		Waakvlambrander	Beluchter	Sproeier MAX		Sproeier MIN		Waakvlambrander
			mm	mm	Opdruk	mm	Opdruk	n°	mm	mm	Opdruk	mm	Opdruk	n°
Direct 60L Indirect 60L	-	-	32	3,00	300	-	-	41	28	1,85	185	-	-	30
Direct 100L Indirect 100L	-	-	33	2,60	260	-	-	41	30	1,65	165	-	-	30
	-	-	34											
Direct 150L Indirect 150L	-	-	34	2,75	275	-	-	41	30	1,75	175	-	-	30
Verwarmingswaarde van minder (Hi) dan			29,25 MJ/m <sup>3</sup>						45,65 MJ/Kg (Gas G30)					
Totaal gasverbruik (met een verwarmingswaarde van minder (Hi) dan 15°C en 1013mbar)														
MODELLEN	+9BSGHINF0		1,72 m <sup>3</sup> /h						1,10 Kg/h					
	+9BSGHDPF0		2,58 m <sup>3</sup> /h						1,66 Kg/h					
	+9BSGHIPF0		2,58 m <sup>3</sup> /h						1,66 Kg/h					
	+9BSGHIPFR		2,58 m <sup>3</sup> /h						1,66 Kg/h					
	+9BSGHDRF0		2,95 m <sup>3</sup> /h						1,89 Kg/h					
	+9BSGHDRFW		2,95 m <sup>3</sup> /h						1,89 Kg/h					
	+9BSGHIRF0		2,95 m <sup>3</sup> /h						1,89 Kg/h					
	+9BSGHIRFR		2,95 m <sup>3</sup> /h						1,89 Kg/h					
	+9BSGHDRFC		2,95 m <sup>3</sup> /h						1,89 Kg/h					
	+9BSGHIRFC		2,95 m <sup>3</sup> /h						1,89 Kg/h					

## PT. PORTUGAL (category II2H3+)

TABELA B - Pressão do gás e dados dos bicos														
TIPO DE GÁS			G20						G30/G31					
			Nominal		Mínima		Máxima		Nominal		Mínima		Máxima	
PRESSÃO DO GÁS		(mbar)	20		17		25		28-30/37		20/25		35/45	
QUEIMADORES	Ø (mm)	kW	Ventilador	Bico MÁX		Bico MÍN		Piloto	Ventilador	Bico MÁX		Bico MÍN		Piloto
			mm	mm	Grav.	mm	Grav.	n°	mm	mm	Grav.	mm	Grav.	n°
Directa 60L Indirecta 60L	- -	- -	32	2,90	290	-	-	41	28	1,85	185	-	-	30
Directa 100L Indirecta 100L	- -	- -	32	2,50	250	-	-	41	30	1,65	165	-	-	30
Directa 150L Indirecta 150L	- -	- -	33	2,60	260	-	-	41	30	1,75	175	-	-	30
Poder calorífico inferior (Hi)			34.02 MJ/m <sup>3</sup>						45.65 MJ/Kg (Gás G30)					
Consumo de gás total (com poder calorífico inferior (Hi) a 15°C e 1013 mbar)														
MODELOS	+9BSGHINF0		1,48 m <sup>3</sup> /h						1,10 Kg/h					
	+9BSGHDPF0		2,22 m <sup>3</sup> /h						1,66 Kg/h					
	+9BSGHIPF0		2,22 m <sup>3</sup> /h						1,66 Kg/h					
	+9BSGHIPFR		2,22 m <sup>3</sup> /h						1,66 Kg/h					
	+9BSGHDRF0		2,54 m <sup>3</sup> /h						1,89 Kg/h					
	+9BSGHDRFW		2,54 m <sup>3</sup> /h						1,89 Kg/h					
	+9BSGHIRF0		2,54 m <sup>3</sup> /h						1,89 Kg/h					
	+9BSGHIRFR		2,54 m <sup>3</sup> /h						1,89 Kg/h					
	+9BSGHIDFC		2,54 m <sup>3</sup> /h						1,89 Kg/h					
	+9BSGHIRFC		2,54 m <sup>3</sup> /h						1,89 Kg/h					

## DK. DENMARK (category II2H3B/P)

TABEL B - Gastryk og tekniske specifikationer for dyser														
GASTYPE			G20						G30/G31					
			Nominal		Minimum		Maksimum		Nominal		Minimum		Maksimum	
GASTRYK		(mbar)	20		17		25		30		25		35	
BRÆNDERE	Ø (mm)	kW	Lufttil- blander	Dyse MAKS.		Dyse MIN.		Tænd- flamme	Lufttil- blander	Dyse MAKS.		Dyse MIN.		Tænd- flamme
			mm	mm	Trykt	mm	Trykt	Antal	mm	mm	Trykt	mm	Trykt	Antal
Direkte 60L Indirekte 60L	- -	- -	32	2,90	290	-	-	41	28	1,85	185	-	-	30
Direkte 100L Indirekte 100L	- -	- -	32	2,50	250	-	-	41	30	1,65	165	-	-	30
Direkte 150L Indirekte 150L	- -	- -	33	2,60	260	-	-	41	30	1,75	175	-	-	30
Mindste varmeeffekt (Hi)			34.02 MJ/m <sup>3</sup>						45.65 MJ/kg (Gas G30)					
Samlet gasforbrug (med mindste varmeeffekt (Hi) ved 15°C og 1013 mbar)														
MODELLER	+9BSGHINF0		1,48 m <sup>3</sup> /h						1,10 Kg/h					
	+9BSGHDPF0		2,22 m <sup>3</sup> /h						1,66 Kg/h					
	+9BSGHIPF0		2,22 m <sup>3</sup> /h						1,66 Kg/h					
	+9BSGHIPFR		2,22 m <sup>3</sup> /h						1,66 Kg/h					
	+9BSGHDRF0		2,54 m <sup>3</sup> /h						1,89 Kg/h					
	+9BSGHDRFW		2,54 m <sup>3</sup> /h						1,89 Kg/h					
	+9BSGHIRF0		2,54 m <sup>3</sup> /h						1,89 Kg/h					
	+9BSGHIRFR		2,54 m <sup>3</sup> /h						1,89 Kg/h					
	+9BSGHIDFC		2,54 m <sup>3</sup> /h						1,89 Kg/h					
	+9BSGHIRFC		2,54 m <sup>3</sup> /h						1,89 Kg/h					

## SE. SWEDEN (category II2H3B/P)

TABELL B - Gastryck och dysdata																
Typ av GAS			G20						G30/G31							
			Nominell		Min.		Max.		Nominell		Min.		Max.			
GASTRYCK		(mbar)	20		17		25		30		25		35			
BRÄNNARE	Ø (mm)	kW	Luftare		Dysa MAX		Dysa MIN		Pilot-brännare	Luftare		Dysa MAX		Dysa MIN		Pilot-brännare
			mm	mm	Märkning	mm	Märkning	Antal		mm	mm	Märkning	mm	Märkning	Antal	
Direkt uppvärmning, 60 l Indirekt uppvärmning, 60 l	-	-	32	2,90	290	-	-	41	28	1,85	185	-	-	30		
	-	-														
Direkt uppvärmning, 100 l Indirekt uppvärmning, 100 l	-	-	32	2,50	250	-	-	41	30	1,65	165	-	-	30		
	-	-														
Direkt uppvärmning, 150 l Indirekt uppvärmning, 150 l	-	-	33	2,60	260	-	-	41	30	1,75	175	-	-	30		
	-	-														
Lägsta värmeeffekt (Hi)			34.02 MJ/m <sup>3</sup>						45.65 MJ/Kg (Gas G30)							
Total gasförbrukning (Beräknad med lägsta värmeeffekt (Hi) 15°C och 1013 mbar)																
MODELLER	+9BSGHINF0		1,48 m <sup>3</sup> /h						1,10 Kg/h							
	+9BSGHDPF0		2,22 m <sup>3</sup> /h						1,66 Kg/h							
	+9BSGHIPF0		2,22 m <sup>3</sup> /h						1,66 Kg/h							
	+9BSGHIPFR		2,22 m <sup>3</sup> /h						1,66 Kg/h							
	+9BSGHDRF0		2,54 m <sup>3</sup> /h						1,89 Kg/h							
	+9BSGHIRF0		2,54 m <sup>3</sup> /h						1,89 Kg/h							
	+9BSGHIRFW		2,54 m <sup>3</sup> /h						1,89 Kg/h							
	+9BSGHIRFR		2,54 m <sup>3</sup> /h						1,89 Kg/h							
	+9BSGHDRFC		2,54 m <sup>3</sup> /h						1,89 Kg/h							
+9BSGHIRFC		2,54 m <sup>3</sup> /h						1,89 Kg/h								

## NO. NORWAY (category II2H3B/P)

TABELL B - Gasstryck og dysedata																
GASSTYPE			G20						G30/G31							
			Nominell		Minimum		Maksimum		Nominell		Minimum		Maksimum			
GASTRYCK		(mbar)	20		17		25		30		25		35			
BRENNERE	Ø (mm)	kW	Ventilator		Dyse MAX		Dyse MIN		Tenner	Ventilator		Dyse MAX		Dyse MIN		Tenner
			mm	mm	mm	Merk.	mm	Merk.		nr	mm	mm	mm	Merk.	mm	
Direkte 60L Indirekte 60L	-	-	32	2,90	290	-	-	41	28	1,85	185	-	-	30		
	-	-														
Direkte 100L Indirekte 100L	-	-	32	2,50	250	-	-	41	30	1,65	165	-	-	30		
	-	-														
Direkte 150L Indirekte 150L	-	-	33	2,60	260	-	-	41	30	1,75	175	-	-	30		
	-	-														
Minste varmeeffekt (Hi)			34.02 MJ/m <sup>3</sup>						45.65 MJ/Kg (Gas G30)							
Totalt gassforbruk (med minste varmeeffekt (Hi) på 15°C og 1013mbar)																
MODELLER	+9BSGHINF0		1,48 m <sup>3</sup> /h						1,10 Kg/h							
	+9BSGHDPF0		2,22 m <sup>3</sup> /h						1,66 Kg/h							
	+9BSGHIPF0		2,22 m <sup>3</sup> /h						1,66 Kg/h							
	+9BSGHIPFR		2,22 m <sup>3</sup> /h						1,66 Kg/h							
	+9BSGHDRF0		2,54 m <sup>3</sup> /h						1,89 Kg/h							
	+9BSGHDRFW		2,54 m <sup>3</sup> /h						1,89 Kg/h							
	+9BSGHIRF0		2,54 m <sup>3</sup> /h						1,89 Kg/h							
	+9BSGHIRFR		2,54 m <sup>3</sup> /h						1,89 Kg/h							
	+9BSGHDRFC		2,54 m <sup>3</sup> /h						1,89 Kg/h							
+9BSGHIRFC		2,54 m <sup>3</sup> /h						1,89 Kg/h								



# AT-CH. AUSTRIA - SWITZERLAND (category II2H3B/P)

TABELLE B - Gasdruck und Daten der Düsen																
GASART			G20						G30/G31							
			Nenndruck		Mindestdruck		Höchstdruck		Nenndruck		Mindestdruck		Höchstdruck			
GASDRUCK		(mbar)	20		18		25		50		42,5		57,5			
BRENNER	Ø (mm)	kW	Lufring		Düse MAX		Düse MIN		Zündflamme	Lufring		Düse MAX		Düse MIN		Zündflamme
			mm	mm	Stempel	mm	Stempel	Anz.	mm	mm	Stempel	mm	Stempel	Anz.		
Direkt beheizt, 60 L	-	-	32	2,90	290	-	-	41	30	1,60	160	-	-	30		
Lindirekt beheizt, 60 L	-	-														
Direkt beheizt, 100 L	-	-	32	2,50	250	-	-	41	33	1,45	145	-	-	30		
Lindirekt beheizt, 100 L	-	-														
Direkt beheizt, 150 L	-	-	33	2,60	260	-	-	41	33	1,55	155	-	-	30		
Lindirekt beheizt, 150 L	-	-														
Unterer Heizwert (Hi)			34.02 Mj/m <sup>3</sup>						45.65 Mj/Kg (Gas G30)							
Gesamtgasverbrauch (mit unterem Heizwert (Hi) bei 15°C und 1013mbar)																
MODELLE	+9BSGHINF0		1,48 m <sup>3</sup> /h						1,10 Kg/h							
	+9BSGHDPF0		2,22 m <sup>3</sup> /h						1,66 Kg/h							
	+9BSGHIPF0		2,22 m <sup>3</sup> /h						1,66 Kg/h							
	+9BSGHIPFR		2,22 m <sup>3</sup> /h						1,66 Kg/h							
	+9BSGHDRF0		2,54 m <sup>3</sup> /h						1,89 Kg/h							
	+9BSGHDRFW		2,54 m <sup>3</sup> /h						1,89 Kg/h							
	+9BSGHIRF0		2,54 m <sup>3</sup> /h						1,89 Kg/h							
	+9BSGHIRFR		2,54 m <sup>3</sup> /h						1,89 Kg/h							
	+9BSGHDRFC		2,54 m <sup>3</sup> /h						1,89 Kg/h							
	+9BSGHIRFC		2,54 m <sup>3</sup> /h						1,89 Kg/h							

# FI. FINLAND (category II2H3B/P)

TAULUKKO B - Kaasun paine ja suuttimien tiedot																
KAASUTYYPPI			G20						G30/G31							
			Nimellinen		Minimi		Maksimi		Nimellinen		Minimi		Maksimi			
KAASUN PAINE		(mbar)	20		17		25		30		25		35			
POLTTIMET	Ø (mm)	kW	Tuuletin		Suutin MAX		Suutin MIN		Sytytysliekki	Tuuletin		Suutin MAX		Suutin MIN		Sytytysliekki
			mm	mm	Merck.	mm	Merck.	nro	mm	mm	Merck.	mm	Merck.	nro		
Suora 60L	-	-	32	2,90	290	-	-	41	28	1,85	185	-	-	30		
Epäsuora 60L	-	-														
Suora 100L	-	-	32	2,50	250	-	-	41	30	1,65	165	-	-	30		
Epäsuora 100L	-	-														
Suora 150L	-	-	33	2,60	260	-	-	41	30	1,75	175	-	-	30		
Epäsuora 150L	-	-														
Alin lämmönkehityskyky (Hi)			34.02 Mj/m <sup>3</sup>						45.65 Mj/Kg (Kaasu G30)							
Kaasun kokonaiskulutus (alin lämmönkehityskyky (Hi) lämpötilassa 15°C ja 1013 mbar)																
MALLIT	+9BSGHINF0		1,48 m <sup>3</sup> /h						1,10 Kg/h							
	+9BSGHDPF0		2,22 m <sup>3</sup> /h						1,66 Kg/h							
	+9BSGHIPF0		2,22 m <sup>3</sup> /h						1,66 Kg/h							
	+9BSGHIPFR		2,22 m <sup>3</sup> /h						1,66 Kg/h							
	+9BSGHDRF0		2,54 m <sup>3</sup> /h						1,89 Kg/h							
	+9BSGHDRFW		2,54 m <sup>3</sup> /h						1,89 Kg/h							
	+9BSGHIRF0		2,54 m <sup>3</sup> /h						1,89 Kg/h							
	+9BSGHIRFR		2,54 m <sup>3</sup> /h						1,89 Kg/h							
	+9BSGHDRFC		2,54 m <sup>3</sup> /h						1,89 Kg/h							
	+9BSGHIRFC		2,54 m <sup>3</sup> /h						1,89 Kg/h							

## EE. ESTONIA (category II2H3B/P)

TABEL B - Andmed gaasi rõhu ja düüsi kohta														
GAASI TÜÜP			G20					G30/G31						
			Nominaal		Min.		Maks.	Nominaal		Min.		Maks.		
GAASI RÕHK		(mbar)	20		17		25			30		25		35
PÕLETID	Ø (mm)	kW	Tuulutaja	MAKS. Düüs		MIN. Düüs		Süüteleek	Tuulutaja	MAKS. Düüs		MIN. Düüs		Süüteleek
			mm	mm	Tempel	mm	Tempel	nr.	mm	mm	Tempel	mm	Tempel	nr.
Otsene 60L Kaudne 60L	-	-	32	2,90	290	-	-	41	28	1,85	185	-	-	30
	-	-												
Otsene 100L Kaudne 100L	-	-	32	2,50	250	-	-	41	30	1,65	165	-	-	30
	-	-												
Otsene 150L Kaudne 150L	-	-	33	2,60	260	-	-	41	30	1,75	175	-	-	30
	-	-												
Alumine kütteväärtus (Hi)			34.02 MJ/m <sup>3</sup>					45,65 MJ/kg (G30 gaas)						
Gaasitarbimine kokku (alumise kütteväärtuse (Hi) 15°C ja 1013 mbaari juures)														
MUDELID	+9BSGHINF0		1,48 m <sup>3</sup> /h					1,10 Kg/h						
	+9BSGHDPF0		2,22 m <sup>3</sup> /h					1,66 Kg/h						
	+9BSGHIPF0		2,22 m <sup>3</sup> /h					1,66 Kg/h						
	+9BSGHIPFR		2,22 m <sup>3</sup> /h					1,66 Kg/h						
	+9BSGHDRF0		2,54 m <sup>3</sup> /h					1,89 Kg/h						
	+9BSGHDRFW		2,54 m <sup>3</sup> /h					1,89 Kg/h						
	+9BSGHIRF0		2,54 m <sup>3</sup> /h					1,89 Kg/h						
	+9BSGHIRFR		2,54 m <sup>3</sup> /h					1,89 Kg/h						
	+9BSGHDRFC		2,54 m <sup>3</sup> /h					1,89 Kg/h						
	+9BSGHIRFC		2,54 m <sup>3</sup> /h					1,89 Kg/h						

## LT. LITHUANIA (category II2H3B/P)

Lentelė B - duomenys apie dujų slėgį ir purkštukus														
DUJŲ TIPAS			G20					G30/G31						
			Nominalus		Min.		Maks.	Nominalus		Min.		Maks.		
DUJŲ SLĖGIS		(mili-barai)	20		17		25			30		25		35
DEGIKLIAI	Ø (mm)	kW	Aerato-rius	MAKS. Purkštukas		MIN. Purkštukas		Pagalbinis vožtuvas	Aerato-rius	MAKS. Purkštukas		MIN. Purkštukas		Pagalbinis vožtuvas
			mm	mm	spaudas	mm	spaudas	nr.	mm	mm	spaudas	mm	spaudas	nr.
Tiesioginis 60 l Netiesioginis 60 l	-	-	32	2,90	290	-	-	41	28	1,85	185	-	-	30
	-	-												
Tiesioginis 100 l Netiesioginis 100 l	-	-	32	2,50	250	-	-	41	30	1,65	165	-	-	30
	-	-												
Tiesioginis 150 l Netiesioginis 150 l	-	-	33	2,60	260	-	-	41	30	1,75	175	-	-	30
	-	-												
Mažesnė kaitinimo galia (Hi)			34.02 MJ/m <sup>3</sup>					45.65 MJ/Kg (Gas G30)						
Bendras dujų sunaudojimas (su mažesne kaitinimo galia (Hi) esant 15° C ir 1013 milibaru)														
MODELIAI	+9BSGHINF0		1,48 m <sup>3</sup> /h					1,10 Kg/h						
	+9BSGHDPF0		2,22 m <sup>3</sup> /h					1,66 Kg/h						
	+9BSGHIPF0		2,22 m <sup>3</sup> /h					1,66 Kg/h						
	+9BSGHIPFR		2,22 m <sup>3</sup> /h					1,66 Kg/h						
	+9BSGHDRF0		2,54 m <sup>3</sup> /h					1,89 Kg/h						
	+9BSGHDRFW		2,54 m <sup>3</sup> /h					1,89 Kg/h						
	+9BSGHIRF0		2,54 m <sup>3</sup> /h					1,89 Kg/h						
	+9BSGHIRFR		2,54 m <sup>3</sup> /h					1,89 Kg/h						
	+9BSGHDRFC		2,54 m <sup>3</sup> /h					1,89 Kg/h						
	+9BSGHIRFC		2,54 m <sup>3</sup> /h					1,89 Kg/h						

## LV. LATVIA (category II2H3B/P)

TABULA B - Gāzes spiediens un uzgaļu dati														
GĀZES VEIDS			G20						G30/G31					
			Sākotnējais		Minimālais		Maksimālais		Sākotnējais		Minimālais		Maksimālais	
GĀZES SPIEDIENS		(mbar)	20		17		25		30		25		35	
DEĢĻI	Ø (mm)	kW	Ventila-tors	Uzgalis MAX		Uzgalis MIN		Signāl-lampīņa	Ventila-tors	Uzgalis MAX		Uzgalis MIN		Signāl-lampīņa
			mm	mm	espiests	mm	lespiests	n°	mm	mm	espiests	mm	lespiests	n°
Tieša 60L Netieša 60L	- -	- -	32	2,90	290	-	-	41	28	1,85	185	-	-	30
Tieša 100L Netieša 100L	- -	- -	32	2,50	250	-	-	41	30	1,65	165	-	-	30
Tieša 150L Netieša 150L	- -	- -	33	2,60	260	-	-	41	30	1,75	175	-	-	30
Mazākā karstuma jauda (Hi)			34.02 Mj/m <sup>3</sup>						45,65 Mj/Kg (Gāze G30)					
Kopējais gāzes patēriņš (ar mazāko karstuma jaudu (Hi) pie 15°C un 1013mbar)														
MODEĻI	+9BSGHINF0		1,48 m <sup>3</sup> /h						1,10 Kg/h					
	+9BSGHDPPF0		2,22 m <sup>3</sup> /h						1,66 Kg/h					
	+9BSGHIPF0		2,22 m <sup>3</sup> /h						1,66 Kg/h					
	+9BSGHIPFR		2,22 m <sup>3</sup> /h						1,66 Kg/h					
	+9BSGHDRF0		2,54 m <sup>3</sup> /h						1,89 Kg/h					
	+9BSGHDRFW		2,54 m <sup>3</sup> /h						1,89 Kg/h					
	+9BSGHIRF0		2,54 m <sup>3</sup> /h						1,89 Kg/h					
	+9BSGHIRFR		2,54 m <sup>3</sup> /h						1,89 Kg/h					
	+9BSGHDRFC		2,54 m <sup>3</sup> /h						1,89 Kg/h					
	+9BSGHIRFC		2,54 m <sup>3</sup> /h						1,89 Kg/h					

## CZ. CZECH REPUBLIC (category II2H3B/P)

TABULKA B - Tlak plynu a údaje trysek														
DRUH PLYNU			G20						G30/G31					
			Jmenovitý		Minimální		Maximální		Jmenovitý		Minimální		Maximální	
TLAK PLYNU		(mbar)	20		17		25		30		25		35	
HOŘÁKY	Ø (mm)	kW	Větrák	Tryska MAX		Tryska MIN		Pilot	Větrák	Tryska MAX		Tryska MIN		Pilot
			mm	mm	Vytišť.	mm	Vytišť.	č	mm	mm	Vytišť.	mm	Vytišť.	č
Pøímý plamen 60 l Nepøímý plamen 60 l	- -	- -	32	2,90	290	-	-	41	28	1,85	185	-	-	30
Pøímý plamen 100 l Nepøímý plamen 100 l	- -	- -	32	2,50	250	-	-	41	30	1,65	165	-	-	30
Pøímý plamen 150 l Nepøímý plamen 150 l	- -	- -	33	2,60	260	-	-	41	30	1,75	175	-	-	30
Tepelný výkon dolní (Hi)			34.02 Mj/m <sup>3</sup>						45.65 Mj/Kg (Plyn G30)					
Celková spotřeba plynu (s dolním tepelným výkonem (Hi) při 15°C a 1013 mbar)														
MODELY	+9BSGHINF0		1,48 m <sup>3</sup> /h						1,10 Kg/h					
	+9BSGHDPPF0		2,22 m <sup>3</sup> /h						1,66 Kg/h					
	+9BSGHIPF0		2,22 m <sup>3</sup> /h						1,66 Kg/h					
	+9BSGHIPFR		2,22 m <sup>3</sup> /h						1,66 Kg/h					
	+9BSGHDRF0		2,54 m <sup>3</sup> /h						1,89 Kg/h					
	+9BSGHDRFW		2,54 m <sup>3</sup> /h						1,89 Kg/h					
	+9BSGHIRF0		2,54 m <sup>3</sup> /h						1,89 Kg/h					
	+9BSGHIRFR		2,54 m <sup>3</sup> /h						1,89 Kg/h					
	+9BSGHDRFC		2,54 m <sup>3</sup> /h						1,89 Kg/h					
	+9BSGHIRFC		2,54 m <sup>3</sup> /h						1,89 Kg/h					

## SK. SLOVAKIA (category II2H3B/P)

TABUĽKA B - Tlak plynu a údaje o dýzách														
DRUH PLYNU			G20						G30/G31					
			Menovitý		Minimálny		Maximálny		Menovitý		Minimálny		Maximálny	
TLAK PLYNU		(mbar)	20		17		25		30		25		35	
HORÁKY	Ø (mm)	kW	Aerátor	Dýza MAX		Dýza MIN		Pilotná	Aerátor	Dýza MAX		Dýza MIN		Pilotná
			mm	mm	Značka	mm	Značka	č	mm	mm	Značka	mm	Značka	č
S priamym ohrevom 60l S vrstveným dnom 60l	-	-	32	2,90	290	-	-	41	28	1,85	185	-	-	30
	-	-												
S priamym ohrevom 100l S vrstveným dnom 100l	-	-	32	2,50	250	-	-	41	30	1,65	165	-	-	30
	-	-												
S priamym ohrevom 150l S vrstveným dnom 150l	-	-	33	2,60	260	-	-	41	30	1,75	175	-	-	30
	-	-												
Spodný tepelný výkon (Hi)			34.02 Mj/m <sup>3</sup>						45.65 Mj/Kg (Plyn G30)					
Celková spotreba plynu (so spodným tepelným výkonom(Hi) pri 15°C a 1013 mbar)														
MODELY	+9BSGHINF0		1,48 m <sup>3</sup> /h						1,10 Kg/h					
	+9BSGHDPF0		2,22 m <sup>3</sup> /h						1,66 Kg/h					
	+9BSGHIPF0		2,22 m <sup>3</sup> /h						1,66 Kg/h					
	+9BSGHIPFR		2,22 m <sup>3</sup> /h						1,66 Kg/h					
	+9BSGHDRF0		2,54 m <sup>3</sup> /h						1,89 Kg/h					
	+9BSGHIRF0		2,54 m <sup>3</sup> /h						1,89 Kg/h					
	+9BSGHIRFW		2,54 m <sup>3</sup> /h						1,89 Kg/h					
	+9BSGHIRFR		2,54 m <sup>3</sup> /h						1,89 Kg/h					
	+9BSGHDRFC		2,54 m <sup>3</sup> /h						1,89 Kg/h					
	+9BSGHIRFC		2,54 m <sup>3</sup> /h						1,89 Kg/h					

## PL. POLAND (category II2E3B/P)

TABELA B - Ciśnienie gazu oraz dane dysz														
TYP GAZU			G20						G30/G31					
			Nominalne		Minimalne		Maksymalne		Nominalne		Minimalne		Maksymalne	
CIŚNIENIE GAZU		(mbar)	20		17		25		36		30		50	
PALNIKI	Ø (mm)	kW	Aerator	Dysza MAX		Dysza a MIN		Pilot	Aerator	Dysza MAX		Dysza MIN		Pilot
			mm	mm	Ozn.	mm	Ozn.	nr	mm	mm	Ozn.	mm	Ozn.	nr
Z grzaniem bezpośrednim 60 l Z grzaniem pośrednim 60 l	-	-	32	2,90	290	-	-	41	30	1,75	175	-	-	30
	-	-												
Z grzaniem bezpośrednim 100 l Z grzaniem pośrednim 100 l	-	-	32	2,50	250	-	-	41	32	1,55	155	-	-	30
	-	-												
Z grzaniem bezpośrednim 150 l Z grzaniem pośrednim 150 l	-	-	33	2,60	260	-	-	41	30	1,65	165	-	-	30
	-	-												
Dolna wartość opałowa (Hi)			34.02 Mj/m <sup>3</sup>						45.65 Mj/Kg (Plyn G30)					
Łączny pobór gazu (o dolnej wartości opałowej (Hi) przy 15°C i 1013 mbar)														
MODELE	+9BSGHINF0		1,48 m <sup>3</sup> /h						1,10 Kg/h					
	+9BSGHDPF0		2,22 m <sup>3</sup> /h						1,66 Kg/h					
	+9BSGHIPF0		2,22 m <sup>3</sup> /h						1,66 Kg/h					
	+9BSGHIPFR		2,22 m <sup>3</sup> /h						1,66 Kg/h					
	+9BSGHDRF0		2,54 m <sup>3</sup> /h						1,89 Kg/h					
	+9BSGHDRFW		2,54 m <sup>3</sup> /h						1,89 Kg/h					
	+9BSGHIRF0		2,54 m <sup>3</sup> /h						1,89 Kg/h					
	+9BSGHIRFR		2,54 m <sup>3</sup> /h						1,89 Kg/h					
	+9BSGHDRFC		2,54 m <sup>3</sup> /h						1,89 Kg/h					
	+9BSGHIRFC		2,54 m <sup>3</sup> /h						1,89 Kg/h					

# HU. HUNGARY (category II2HS3B/P)

B. TÁBLÁZAT - Gáznyomás és fűvókaadatok																						
GÁZFAJTA			G20						G30/G31						G25.1							
			Névleges	Minimum	Maximum	Névleges	Minimum	Maximum	Névleges	Minimum	Maximum	Névleges	Minimum	Maximum								
GÁZNYOMÁS		(mbar)	25		20		30		30		25		35		25		30					
ÉGŐK	Ø (mm)	kW	Levegőtétő		Fűvóka MAX		Fűvóka MIN		Gyűjtőláng		Levegőtétő		Fűvóka MAX		Fűvóka MIN		Gyűjtőláng					
			mm	mm	mm	Nyomt.	mm	Nyomt.	szám	mm	mm	mm	Nyomt.	mm	Nyomt.	mm	Nyomt.	szám				
Közvetlen 60 liter Közvetlen 60 liter	-	-	33	2,70	270	-	-	-	41	28	1,85	185	-	-	-	30	35	3,00	300	-	-	41
	-	-	32	2,35	235	-	-	-	41	30	1,65	165	-	-	-	30	34	2,60	260	-	-	41
	-	-	33	2,45	245	-	-	-	41	30	1,75	175	-	-	-	30	34	2,75	275	-	-	41
Közvetlen 100 liter Közvetlen 100 liter			34,02 MJ/m <sup>3</sup>			45,65 MJ/Kg (Gas G30)			29,30 MJ/m <sup>3</sup>													
Közvetlen 150 liter Közvetlen 150 liter			34,02 MJ/m <sup>3</sup>			45,65 MJ/Kg (Gas G30)			29,30 MJ/m <sup>3</sup>													
Alsó hőteljesítmény (Hi)			34,02 MJ/m <sup>3</sup>			45,65 MJ/Kg (Gas G30)			29,30 MJ/m <sup>3</sup>													
Összesített gázfogyasztás (15°C és 1013 mbar melletti alsó hőértéknél (Hi))			34,02 MJ/m <sup>3</sup>			45,65 MJ/Kg (Gas G30)			29,30 MJ/m <sup>3</sup>													
TÍPUSOK			+9BSGHINF0	1,48 m <sup>3</sup> /h	1,10 Kg/h	1,72 m <sup>3</sup> /h																
			+9BSGHDPF0	2,22 m <sup>3</sup> /h	1,66 Kg/h	2,58 m <sup>3</sup> /h																
			+9BSGHIPF0	2,22 m <sup>3</sup> /h	1,66 Kg/h	2,58 m <sup>3</sup> /h																
			+9BSGHIPFR	2,22 m <sup>3</sup> /h	1,66 Kg/h	2,58 m <sup>3</sup> /h																
			+9BSGHDRF0	2,54 m <sup>3</sup> /h	1,89 Kg/h	2,95 m <sup>3</sup> /h																
			+9BSGHDRFW	2,54 m <sup>3</sup> /h	1,89 Kg/h	2,95 m <sup>3</sup> /h																
			+9BSGHIRF0	2,54 m <sup>3</sup> /h	1,89 Kg/h	2,95 m <sup>3</sup> /h																
+9BSGHIRFR			2,54 m <sup>3</sup> /h	1,89 Kg/h	2,95 m <sup>3</sup> /h																	
+9BSGHDRFC			2,54 m <sup>3</sup> /h	1,89 Kg/h	2,95 m <sup>3</sup> /h																	
+9BSGHIRFC			2,54 m <sup>3</sup> /h	1,89 Kg/h	2,95 m <sup>3</sup> /h																	

# SI. SLOVENIA (category II2H3B/P)

TABELA B - tlak plina in podatki o šobah														
VRSTA PLINA			G20						G30/G31					
			Naz ivna		Najmanjša		Največja		Naz ivna		Najmanjša		Največja	
TLAK PLINA		(mbar)	20		17		25		30		25		35	
GORILNIKI	Ø (mm)	kW	Zračnik	Šoba MAKS		Šoba MIN		Pilot	Zračnik	Šoba MAKS		Šoba MIN		Pilot
			mm	mm	Žig	mm	Žig	št	mm	mm	Žig	mm	Žig	št
Neposredna 60L Posrdna 60L		- -	32	2,90	290	-	-	41	28	1,85	185	-	-	30
Neposredna 100L Posrdna 100L		- -	32	2,50	250	-	-	41	30	1,65	165	-	-	30
Neposredna 150L Posrdna 150L		- -	33	2,60	260	-	-	41	30	1,75	175	-	-	30
Spodnja kalorična moč (Hi)			34.02 MJ/m <sup>3</sup>						45.65 MJ/Kg (plin G30)					
Skupna potrošnja plina (pri spodnji kalorični moči (Hi) pri 15°C in 1013mbar)														
MODELI	+9BSGHINF0		1,48 m <sup>3</sup> /h						1,10 Kg/h					
	+9BSGHDPF0		2,22 m <sup>3</sup> /h						1,66 Kg/h					
	+9BSGHIPF0		2,22 m <sup>3</sup> /h						1,66 Kg/h					
	+9BSGHIPFR		2,22 m <sup>3</sup> /h						1,66 Kg/h					
	+9BSGHDRF0		2,54 m <sup>3</sup> /h						1,89 Kg/h					
	+9BSGHDRFW		2,54 m <sup>3</sup> /h						1,89 Kg/h					
	+9BSGHIRF0		2,54 m <sup>3</sup> /h						1,89 Kg/h					
	+9BSGHIRFR		2,54 m <sup>3</sup> /h						1,89 Kg/h					
	+9BSGHDRFC		2,54 m <sup>3</sup> /h						1,89 Kg/h					
+9BSGHIRFC		2,54 m <sup>3</sup> /h						1,89 Kg/h						

# GR. GREECE (category II2H3+)

ΠΙΝΑΚΑΣ Β - Πίεση αερίου και χαρακτηριστικά των μπεκ														
ΤΥΠΟΣ ΑΕΡΙΟΥ			G20						G30/G31					
			Ονομαστική		Ελάχιστη		Μέγιστη		Ονομαστική		Ελάχιστη		Μέγιστη	
ΠΙΕΣΗ ΑΕΡΙΟΥ		(mbar)	20		17		25		28-30/37		20/25		35/45	
ΚΑΥΣΤΗΡΕΣ	Ø (mm)	kW	Ανοίγμα	ΜΕΓ. Μπεκ		ΕΛΑΧ. Μπεκ		Καυστήρας ανάφλεξης	Ανοίγμα	ΜΕΓ. Μπεκ		ΕΛΑΧ. Μπεκ		Καυστήρας ανάφλεξης
			mm	mm	Ένδειξη.	mm	Ένδειξη.	αριθ	mm	mm	Ένδειξη.	mm	Ένδειξη.	αριθ
Άμεσης θέρμανσης 60L Έμμεσης θέρμανσης 60L		- -	32	2,90	290	-	-	41	28	1,85	185	-	-	30
Άμεσης θέρμανσης 100L Έμμεσης θέρμανσης 100L		- -	32	2,50	250	-	-	41	30	1,65	165	-	-	30
Άμεσης θέρμανσης 150L Έμμεσης θέρμανσης 150L		- -	33	2,60	260	-	-	41	30	1,75	175	-	-	30
Κατώτερη θερμαντική ισχύς (Hi)			34.02 MJ/m <sup>3</sup>						45.65 MJ/Kg (Αέριο G30)					
Συνολική κατανάλωση αερίου (με κατώτερη θερμαντική ισχύ (Hi) στους 15°C και 1013mbar)														
ΜΟΝΤΕΛΑ	+9BSGHINF0		1,48 m <sup>3</sup> /h						1,10 Kg/h					
	+9BSGHDPF0		2,22 m <sup>3</sup> /h						1,66 Kg/h					
	+9BSGHIPF0		2,22 m <sup>3</sup> /h						1,66 Kg/h					
	+9BSGHIPFR		2,22 m <sup>3</sup> /h						1,66 Kg/h					
	+9BSGHDRF0		2,54 m <sup>3</sup> /h						1,89 Kg/h					
	+9BSGHDRFW		2,54 m <sup>3</sup> /h						1,89 Kg/h					
	+9BSGHIRF0		2,54 m <sup>3</sup> /h						1,89 Kg/h					
	+9BSGHIRFR		2,54 m <sup>3</sup> /h						1,89 Kg/h					
	+9BSGHDRFC		2,54 m <sup>3</sup> /h						1,89 Kg/h					
+9BSGHIRFC		2,54 m <sup>3</sup> /h						1,89 Kg/h						

## IS-MT. ISLAND - MALTA (category I3B/P)

TAFLA B - Gasþrýstingur og upplýsingar um gasstúta (spíssa)								
GASTEGUND			G30/G31					
			Nafngildi		Minnst		Mest	
GASÞRÝSTINGUR		(mbar)	30		25		35	
BRENNARAR	Ø (mm)	kW	Loftblöndun	Stútur mest		Stútur minnst		Vaktari
			gur	mm	mm	Þrykkt	mm	Þrykkt
Beinn 60L Óbeinn 60L	-	-	28	1,85	185	-	-	30
	-	-						
Beinn 100L Óbeinn 100L	-	-	30	1,65	165	-	-	30
	-	-						
Beinn 150L Óbeinn 150L	-	-	30	1,75	175	-	-	30
	-	-						
Minnsta varmagildi (Hi)			45.65 Mj/Kg (Aéþro G30)					
Heildar gasnotkun (reiknað við minnsta varmagildi (Hi) við 15°C og 1013 mbar)								
TEGUND	+9BSGHINF0		1,10 Kg/h					
	+9BSGHDPF0		1,66 Kg/h					
	+9BSGHIPF0		1,66 Kg/h					
	+9BSGHIPFR		1,66 Kg/h					
	+9BSGHDRF0		1,89 Kg/h					
	+9BSGHDRFW		1,89 Kg/h					
	+9BSGHIRF0		1,89 Kg/h					
	+9BSGHIRFR		1,89 Kg/h					
	+9BSGHDRFC		1,89 Kg/h					
+9BSGHIRFC		1,89 Kg/h						

## LU. LUXEMBOURG (category I2E)

TABLEAU B - Pression du gaz et caractéristiques des buses								
TYPE DE GAZ			G20					
			Nominale		Minimum		Maximum	
PRESSION DU GAZ		(mbar)	20/25		17/20		25/30	
BRÛLEURS	Ø (mm)	kW	Aérateur	Buse MAX		Buse MIN		Veilleuse gaz
			mm	mm	Estamp.	mm	Estamp.	n°
Directe 60L Indirecte 60L	-	-	32	2,90	290	-	-	41
	-	-						
Directe 100L Indirecte 100L	-	-	32	2,50	250	-	-	41
	-	-						
Directe 150L Indirecte 150L	-	-	33	2,60	260	-	-	41
	-	-						
Pouvoir calorifique inférieur (Hi)			34,02 Mj/m3					
Consommation totale de gaz (avec un pouvoir calorifique inférieur (Hi) à 15°C et 1013 mbars)								
MODÈLES	+9BSGHINF0		1,48 m3/h					
	+9BSGHDPF0		2,22 m3/h					
	+9BSGHIPF0		2,22 m3/h					
	+9BSGHIPFR		2,22 m3/h					
	+9BSGHDRF0		2,54 m3/h					
	+9BSGHDRFW		2,54 m3/h					
	+9BSGHIRF0		2,54 m3/h					
	+9BSGHIRFR		2,54 m3/h					
	+9BSGHDRFC		2,54 m3/h					
+9BSGHIRFC		2,54 m3/h						

## CY. CYPRUS (category I3B/P)

ΠΙΝΑΚΑΣ Β - Πίεση αερίου και χαρακτηριστικά των μπεκ								
ΤΥΠΟΣ ΑΕΡΙΟΥ			G30/G31					
			Ονομαστική		Ελάχιστη		Μέγιστη	
ΠΙΕΣΗ ΑΕΡΙΟΥ		(mbar)	28-30/37		20/25		35/45	
ΚΑΥΣΤΗΡΕΣ	Ø (mm)	kW	Άνοιγμα	ΜΕΓ. Μπεκ		ΕΛΑΧ. Μπεκ		Καυστήρας ανάφλεξης
			mm	mm	Ένδειξη.	mm	Ένδειξη.	αριθ
Άμεσης θέρμανσης 60L Έμμεσης θέρμανσης 60L	-	-	28	1,85	185	-	-	30
	-	-						
Άμεσης θέρμανσης 100L Έμμεσης θέρμανσης 100L	-	-	30	1,65	165	-	-	30
	-	-						
Άμεσης θέρμανσης 150L Έμμεσης θέρμανσης 150L	-	-	30	1,75	175	-	-	30
	-	-						
Κατώτερη θερμαντική ισχύς (Hi)			45.65 MJ/Kg (Αέριο G30)					
Συνολική κατανάλωση αερίου (με κατώτερη θερμαντική ισχύ (Hi) στους 15°C και 1013mbar)								
ΜΟΝΤΕΛΑ	+9BSGHINF0		1,10 Kg/h					
	+9BSGHDPF0		1,66 Kg/h					
	+9BSGHIPF0		1,66 Kg/h					
	+9BSGHIPFR		1,66 Kg/h					
	+9BSGHDRF0		1,89 Kg/h					
	+9BSGHDRFW		1,89 Kg/h					
	+9BSGHIRF0		1,89 Kg/h					
	+9BSGHIRFR		1,89 Kg/h					
	+9BSGHDRFC		1,89 Kg/h					
	+9BSGHIRFC		1,89 Kg/h					

## BG. BULGARIA (category II2H3B/P)

ТАБЛИЦА В - Налягане на газта и данни на дюзите																		
ΤΙΠ НА ΓΑΖΤΑ			G20						G30/G31									
			Номинално		Минимално		Максимално		Номинално		Минимално		Максимално					
НАЛЯΓΑΝΕ НА ΓΑΖΤΑ		(mbar)	20		17		25		30		25		35					
ГОРЕЛКИ	Ø (mm)	kW	Аератор		Дюза MAX		Дюза MIN		Водач		Аератор		Дюза MAX		Дюза MIN		Водач	
			mm	Per.	mm	Per.	mm	Per.	mm	Per.	mm	Per.	mm	Per.	mm	Per.	mm	Per.
Директна 60 л Инди́ректна 60 л	-	-	32	2,90	290	-	-	41	28	1,85	185	-	-	30				
	-	-																
Директна 100 л Инди́ректна 100 л	-	-	32	2,50	250	-	-	41	30	1,65	165	-	-	30				
	-	-																
Директна 150 л Инди́ректна 150 л	-	-	33	2,60	260	-	-	41	30	1,75	175	-	-	30				
	-	-																
Долна топлина на изгаряне (Hi)			34.02 MJ/m <sup>3</sup>						45,65 MJ/Kg (Ααc G30)									
Общо потребление на газ (с долна топлина на изгаряне (Hi) при 15°C и 1013 mbar)																		
ΜΟΝΕΛΙ	+9BSGHINF0		1,48 m <sup>3</sup> /h						1,10 Kg/h									
	+9BSGHDPF0		2,22 m <sup>3</sup> /h						1,66 Kg/h									
	+9BSGHIPF0		2,22 m <sup>3</sup> /h						1,66 Kg/h									
	+9BSGHIPFR		2,22 m <sup>3</sup> /h						1,66 Kg/h									
	+9BSGHDRF0		2,54 m <sup>3</sup> /h						1,89 Kg/h									
	+9BSGHDRFW		2,54 m <sup>3</sup> /h						1,89 Kg/h									
	+9BSGHIRF0		2,54 m <sup>3</sup> /h						1,89 Kg/h									
	+9BSGHIRFR		2,54 m <sup>3</sup> /h						1,89 Kg/h									
	+9BSGHDRFC		2,54 m <sup>3</sup> /h						1,89 Kg/h									
	+9BSGHIRFC		2,54 m <sup>3</sup> /h						1,89 Kg/h									



## RO. ROMANIA (category II2H3B/P)

TABELUL B - Presiune gaz <sup>2</sup> i date duze																
TIP GAZ			G20						G30/G31							
			Nominală		Minimă		Maximă		Nominală		Minimă		Maximă			
PRESIUNE GAZ		(mbar)	20		17		25		30		25		35			
ARZĂTOARE	Ø (mm)	kW	Aerator		Duză MAX		Duză MIN		Pilot	Aerator		Duză MAX		Duză MIN		Pilot
			mm	mm	Marcat	mm	Marcat	nr.		mm	mm	Marcat	mm	Marcat	nr.	
Oală cu fund normal 60L	-	-	32	2,90	290	-	-	41	28	1,85	185	-	-	30		
Oală cu fund dublu 60L	-	-														
Oală cu fund normal 100L	-	-	32	2,50	250	-	-	41	30	1,65	165	-	-	30		
Oală cu fund dublu 100L	-	-														
Oală cu fund normal 150L	-	-	33	2,60	260	-	-	41	30	1,75	175	-	-	30		
Oală cu fund dublu 150L	-	-														
Putere calorifică inferioară (Hi)			34.02 Mj/m <sup>3</sup>						45.65 Mj/Kg (Gas G30)							
Consum gaz total (cu putere calorifică inferioară (Hi) la 15°C <sup>2</sup> i 1013mbar)																
MODELE	+9BSGHINF0		1,48 m <sup>3</sup> /h						1,10 Kg/h							
	+9BSGHDPF0		2,22 m <sup>3</sup> /h						1,66 Kg/h							
	+9BSGHIPF0		2,22 m <sup>3</sup> /h						1,66 Kg/h							
	+9BSGHIPFR		2,22 m <sup>3</sup> /h						1,66 Kg/h							
	+9BSGHDRF0		2,54 m <sup>3</sup> /h						1,89 Kg/h							
	+9BSGHDRFW		2,54 m <sup>3</sup> /h						1,89 Kg/h							
	+9BSGHIRF0		2,54 m <sup>3</sup> /h						1,89 Kg/h							
	+9BSGHIRFR		2,54 m <sup>3</sup> /h						1,89 Kg/h							
	+9BSGHDRFC		2,54 m <sup>3</sup> /h						1,89 Kg/h							
	+9BSGHIRFC		2,54 m <sup>3</sup> /h						1,89 Kg/h							

## TR. TURKEY (category II2H3B/P)

TABLO B - Gaz basıncı ve ayar uçları verileri																
GAZ TYPY			G20						G30/G31							
			Nominal		Minimum		Maksimum		Nominal		Minimum		Maksimum			
GAZ BASINCI		(mbar)	20		17		25		30		25		35			
BRÜLÖR	Ø (mm)	kW	Havalan-dırıcı		Ayar ucu MAKS.		Ayar ucu MYN.		Pilot	Havalan-dırıcı		Ayar ucu MAKS.		Ayar ucu MYN.		Pilot
			mm	mm	Bas.	mm	Bas.	sayısı		mm	mm	Bas.	mm	Bas.	sayısı	
Direk 60L	-	-	32	2,90	290	-	-	41	28	1,85	185	-	-	30		
Dolaylı 60L	-	-														
Direk 100L	-	-	32	2,50	250	-	-	41	30	1,65	165	-	-	30		
Dolaylı 100L	-	-														
Direk 150L	-	-	33	2,60	260	-	-	41	30	1,75	175	-	-	30		
Dolaylı 150L	-	-														
Alt ısıtma değeri (Hi)			34.02 Mj/m <sup>3</sup>						45.65 Mj/Kg (Gaz G30)							
Toplam gaz tüketimi (alt ısıtma değeri (Hi) 15°C ve 1013mbar durumunda)																
MODELLER	+9BSGHINF0		1,48 m <sup>3</sup> /h						1,10 Kg/h							
	+9BSGHDPF0		2,22 m <sup>3</sup> /h						1,66 Kg/h							
	+9BSGHIPF0		2,22 m <sup>3</sup> /h						1,66 Kg/h							
	+9BSGHIPFR		2,22 m <sup>3</sup> /h						1,66 Kg/h							
	+9BSGHDRF0		2,54 m <sup>3</sup> /h						1,89 Kg/h							
	+9BSGHDRFW		2,54 m <sup>3</sup> /h						1,89 Kg/h							
	+9BSGHIRF0		2,54 m <sup>3</sup> /h						1,89 Kg/h							
	+9BSGHIRFR		2,54 m <sup>3</sup> /h						1,89 Kg/h							
	+9BSGHDRFC		2,54 m <sup>3</sup> /h						1,89 Kg/h							
	+9BSGHIRFC		2,54 m <sup>3</sup> /h						1,89 Kg/h							