

The logo features the brand name "CombiSteel" in a bold, black, sans-serif font. The text is centered and enclosed within a thick, black, curved border that forms an oval shape.

**CombiSteel**

---

---

**NEUTRAL DISPLAY  
UNIT**

---

---

**INSTRUCTION AND  
MAINTENANCE MANUAL**

*“Professionally with Professionals”*

## DESCRIPTIONS

- Your preferred COMBISTEEL, nature and technology are friendly, thank you for your choice.
- COMBISTEEL, has been produced with the concept of ‘‘Total Quality’’ in modern production facilities.

### Security Alerts

- **Read this manual carefully and keep it future review.**
- **WARNING:** Installation of the devices must be done by authorized service person.
- **WARNING:** Equipment must be grounded.



Indicates that there is a risk of personal injury or property damage.



Explosion / fire hazard.

1. International warranty period is one (1) year from the date of delivery of the product.
2. All of our products, including all parts, are under our warranty.
3. If the product malfunctions within the warranty period, the repair time is added to the warranty period. The repair period is no more than thirty (30) days.
4. Within the warranty period, the product will be repaired without any charge for labor, cost, replacement parts, or any other name due to material or installation errors.
5. The defects arising from the usage of the product contrary to the installation, use and maintenance rules are not covered by the warranty.
6. Saving of the old parts replaced with the new warranty is reserved by.
7. Damage to the internal components of the product or part due to risk, damage and malfunctions that may occur in the following situations and damage to the material and moral damages that may be experienced by the users. All technical, administrative, financial, criminal liability belongs to the user.
  - a. For electrically operated products; without connecting to a grounding system, under overvoltage changes or under inappropriate voltage, under faulty electrical installation and by means of a leakage current relay and electrical supply connection to a main control panel which does not have any groups of fuses.
  - b. Exposure to destructive synthetic chemical substances.
  - c. Exchanging, moving, accidents and neglecting outside the service authorized service personal.
  - d. To be used by inexperienced persons, to make use of mistakes.
  - e. Breaking and scratching the exterior of the product within the customer's responsibility.
  - f. Operation or use of the product in contradiction with the instructions given in the installation, use and maintenance instructions.
  - g. Operation of the product other than authorized service, repair.
  - h. Removing the labels on the product, destroying the serial number.
  - i. Strike with natural disasters such as fire, earthquake, flood, lightning, to stay in lockout environment, damage.
8. Electrical products; the main control panel which provides the electricity to the product without proper grounding installation, and the leakage current relay should not be operated without installing the insurance groups.
9. In order to use the products they purchase, the product users are obliged to provide a safe working environment by first fully completing the job security laws, regulations and regulations.

## INSTALLATION AND USAGE

### 1- Transport

- When transporting, do not deposit the Neutral Display Unit strictly.
- With appropriate transport means, the Neutral Display Unit must be transported without any damage.

### 2- Cleaning and Maintenance

- Do not wash the device with high pressure water.
- Always disconnect power from the device before starting cleaning or maintenance activities.
- At the end of each working day, wipe the device with a cloth soaked in warm soapy water before it cools completely.
- While cleaning the surface of the product, do not use products such as detergent, wire brush and chemical cleaner on stainless surfaces.
- Waiting for a while on materials such as salt and salt water may cause rust on stainless steel surfaces. Therefore, avoid such accumulations. Avoid prolonged contact of foodstuffs containing salt solution with steel surfaces. Never use it on steel surfaces since the water used in some areas (such as well water, artesian) can be salty.
- If the device will not be used for a long period, coat the surfaces with a thin layer of Vaseline.
- In case of any unusual situation in the device, notify the authorized service. Never allow unqualified persons to interfere with the device.

### 3- Operating the Device

- Make a general cleaning before you start. You can use soapy water.
- Turn the switch  on the control panel and make sure that the red signal lamp on it is on. If the signal lamp is not lit, it means that the unit is not energized. It is activate the unit light.
- **For all other settings, contact the authorized service.**

### 4- Drop-in Neutral Display Unit Warnings ; Suggestions

- The device is designed for professional use and should only be used by persons trained in this area.
- If any malfunction occurs in the device, turn off the fuse and electrical connection.
- Only call authorized services for maintenance and use original spare parts.
- Carefully clean the surfaces before using the device.
- The instructions in this manual contain important information on the safe mounting, usage, cleaning and maintenance of the device. Thus, keep the manual at a place easily accessible by the person who will use the machine, and the technician.
- Manufacturer Company accepts no responsibility for the final damages that are caused by any procedure not conforming to the instruction manual, or maintenance or technical interventions that are not performed by authorized people.
- Grounding screw is indicated with a label on the device. "  "

**Control Panel Scheme:**

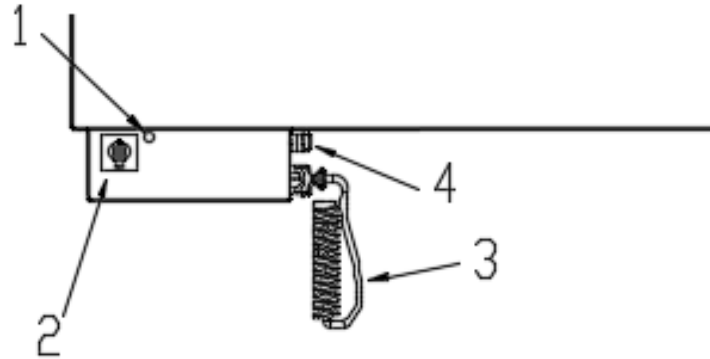

- 1-Signal Indicator (Red)*
- 2-Main Switch*
- 3-Plug Cable*
- 4-Cable Gland*

**Fig. (A)**

<b>Model</b>	<b>Width (A)</b>	<b>Depth (B)</b>	<b>Height (C)</b>	<b>Electrical Inlet</b>	<b>Cable Sections (mm<sup>2</sup>)</b>
7178.2030	1100	730	890	230V 1N PE	3 x 1,5
	1400	730	890	230V 1N PE	3 x 1,5

*Note: All the dimensions are given in mm.*

### 7178.2030

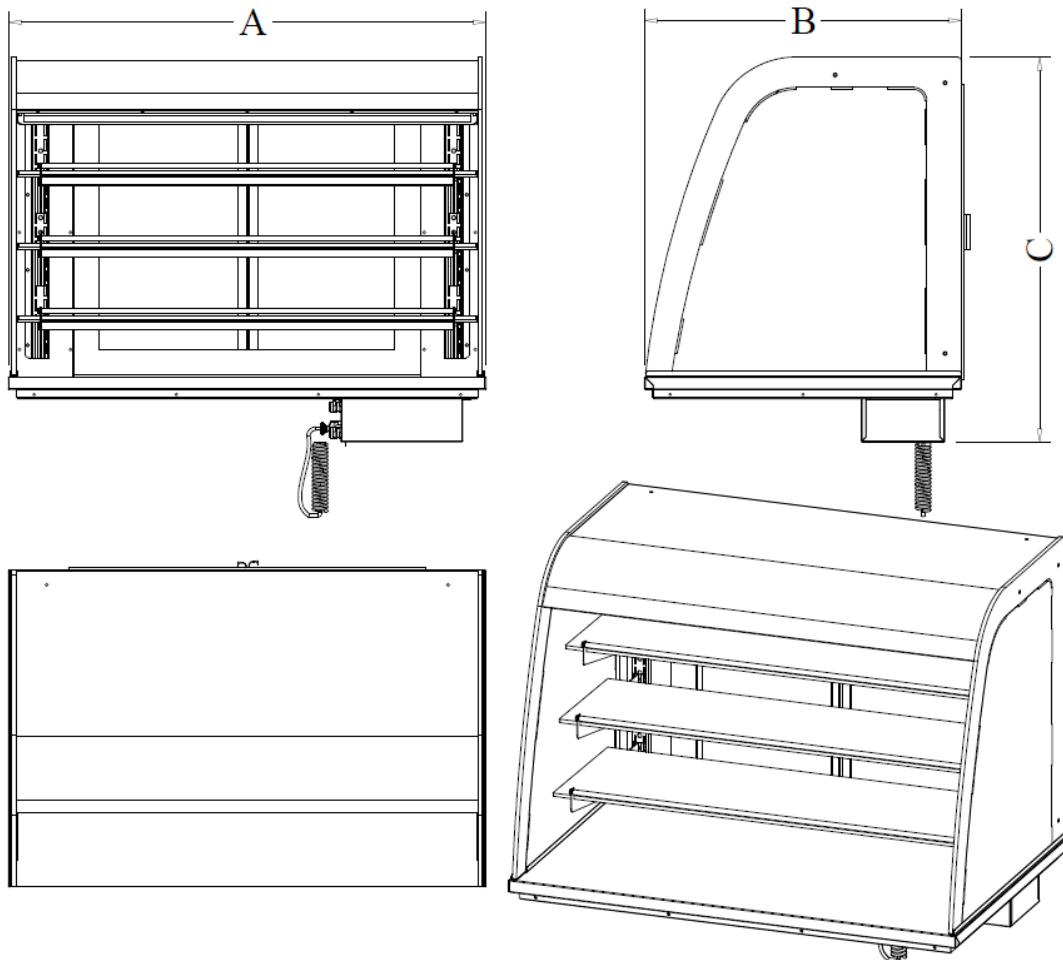

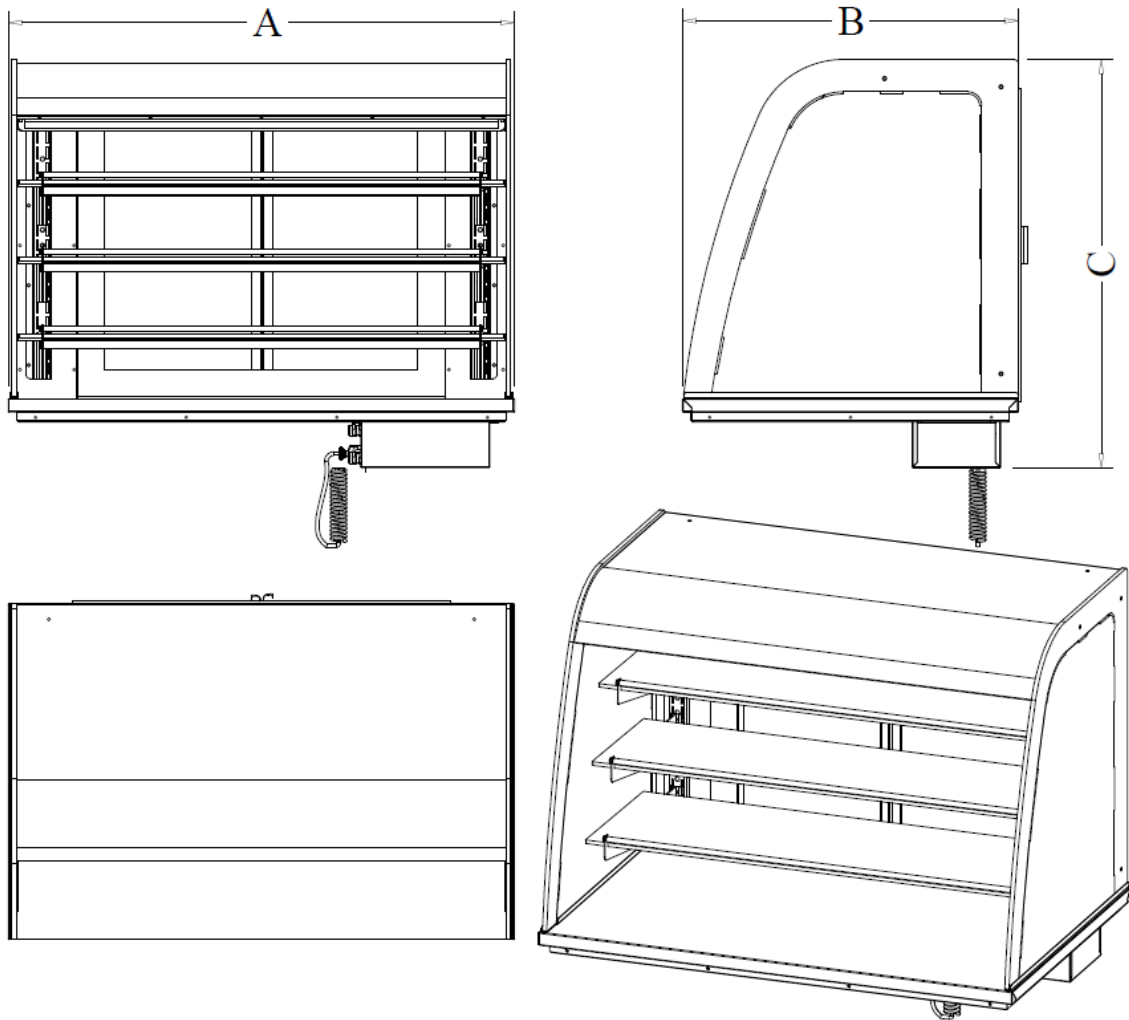

- Limitation of Liability: All technical information contained in this manual, operating instructions, operation and maintenance of the device, contains the latest information on your device. The manufacturer accepts no responsibility for damage or injury which may result from failure to follow the instructions in this manual, use outside of the intended use, unauthorized repair, unauthorized modifications to the device, or use of spare parts not approved by the manufacturer.



## **Combisteel BV**

Office: Lichtschip 63, 3991 CP, Houten, The Netherlands

Warehouse: Verlengde Gildenweg 20, 8304 BK, Emmeloord,  
The Netherlands

TEL: +31 (0)30 285 00 90

E-mail: [info@combisteel.com](mailto:info@combisteel.com)

[www.combisteel.com](http://www.combisteel.com)